

CADD APPLICATIONS, DIGITAL AND RAPID PROTOTYPING

Thomas Pringle

Drafting Program Head

Thomas Nelson Community College

pringlet@tncc.edu



NATIONAL
EDUCATORS
WORKSHOP



GOVERNOR'S ACADEMY
Innovation, Technology and Engineering



OLD SCHOOL



WHAT MY OFFICE LOOKED LIKE



DRAFTING ROOMS OF TODAY



CADD CLASSROOM ENVIRONMENTS



3-D IMAGES OF TODAY

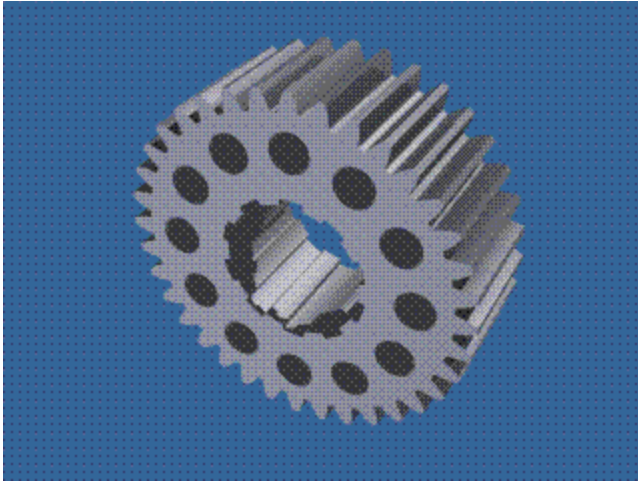



Caution
Traffic
Ahead

DIGITAL PROTOTYPING

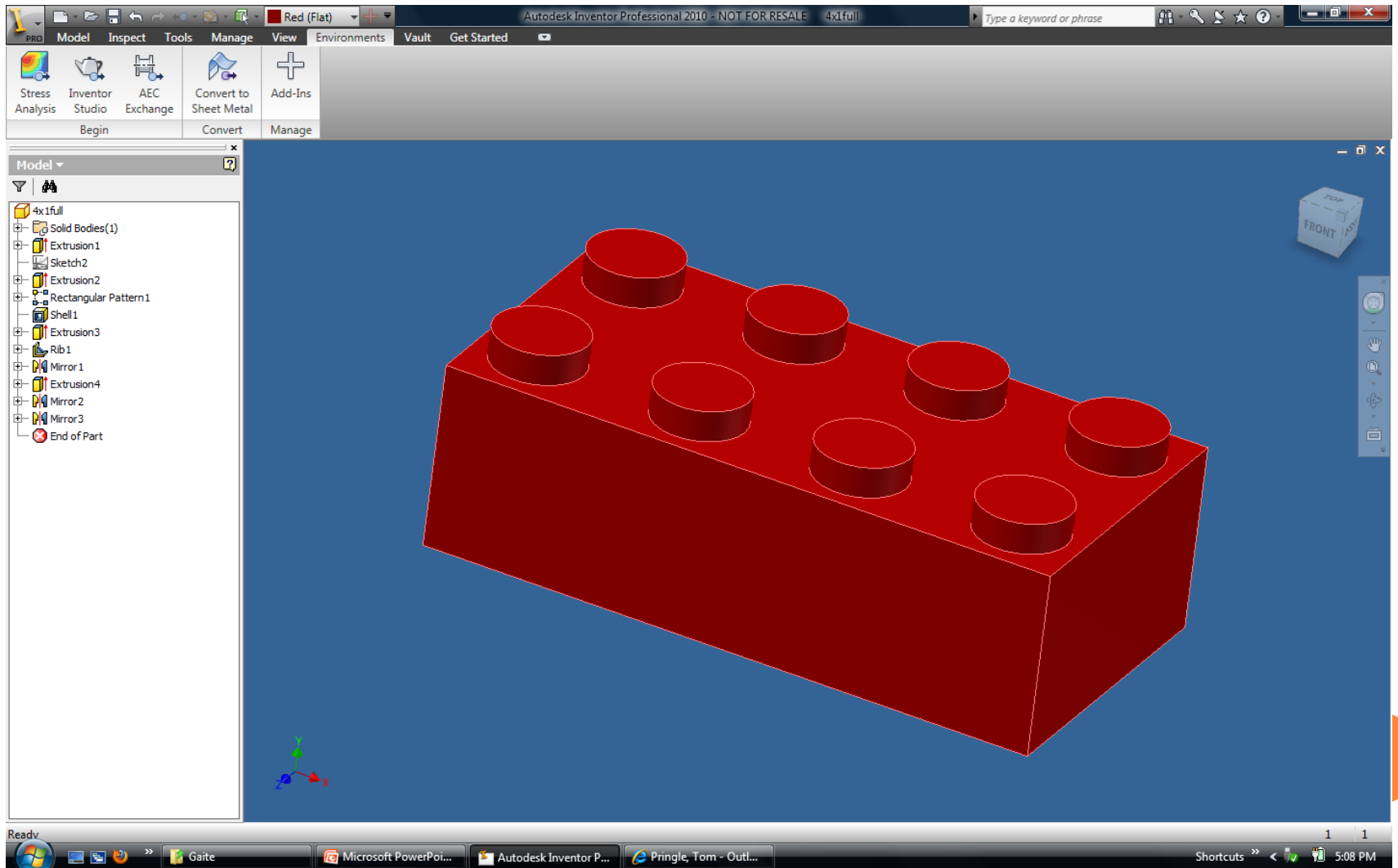

LOOKS LIKE A LEGO®

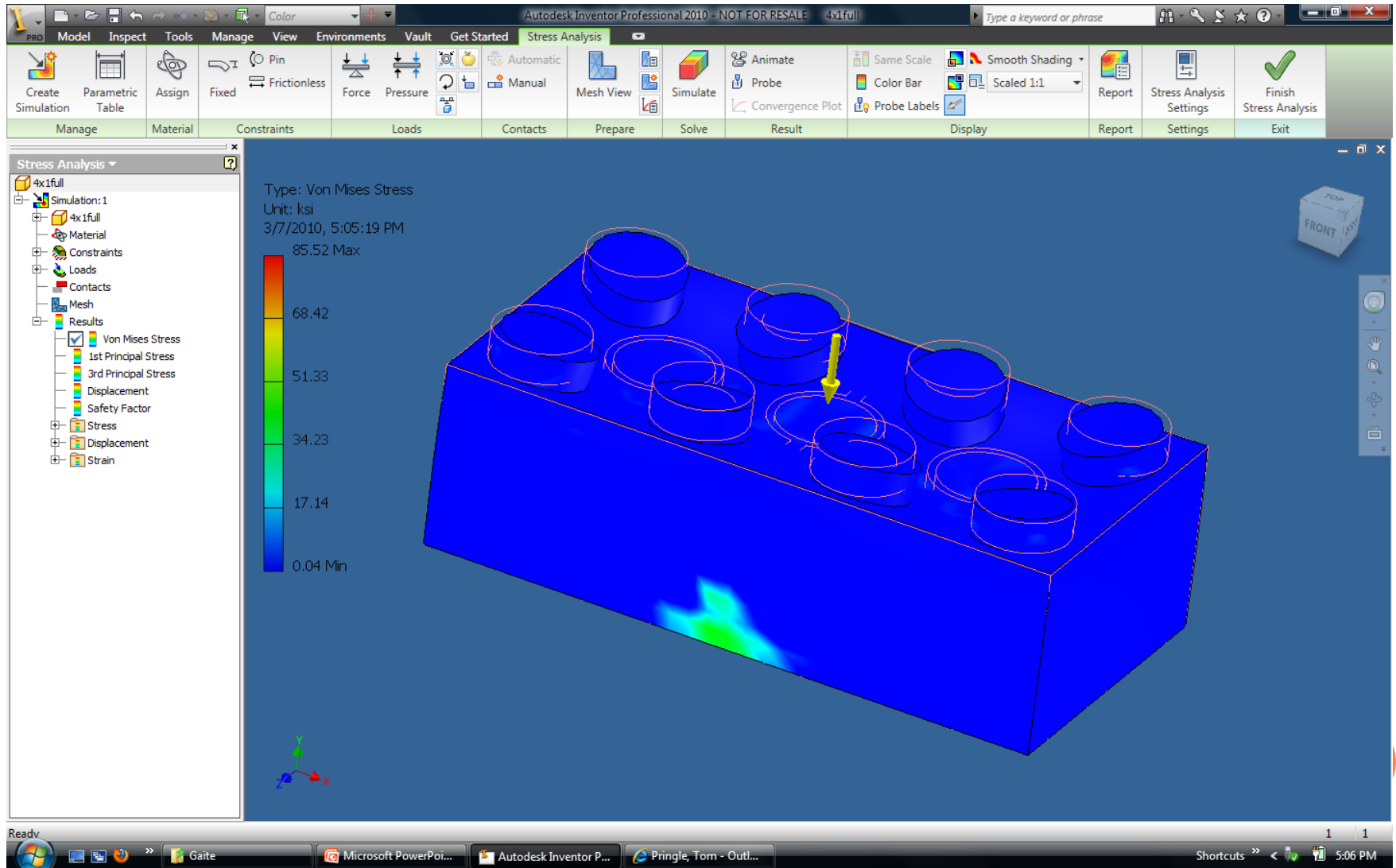

Model Inspect Tools Manage View Environments Vault Get Started Stress Analysis

Parametric Table Assign Fixed Frictionless Force Pressure Automatic Manual Mesh View Simulate Animate Probe Same Scale Color Bar Smooth Shading Scaled 1:1 Probe Labels

Manage Material Constraints Loads Contacts Prepare Solve Result Display Report Settings

Save Reminder
4x1full and its dependents have been saved recently. Click here to save. Don't show me this again.

Analysis

- Simulation: 1
- 4x1full
- Material
- Constraints
- Loads
- Contacts
- Mesh
- Results
 - Von Mises Stress
 - 1st Principal Stress
 - 3rd Principal Stress
 - Displacement
 - Safety Factor
 - Stress
 - Displacement
 - Strain

Type: Von Mises Stress
Unit: ksi
3/7/2010, 5:08:40 PM

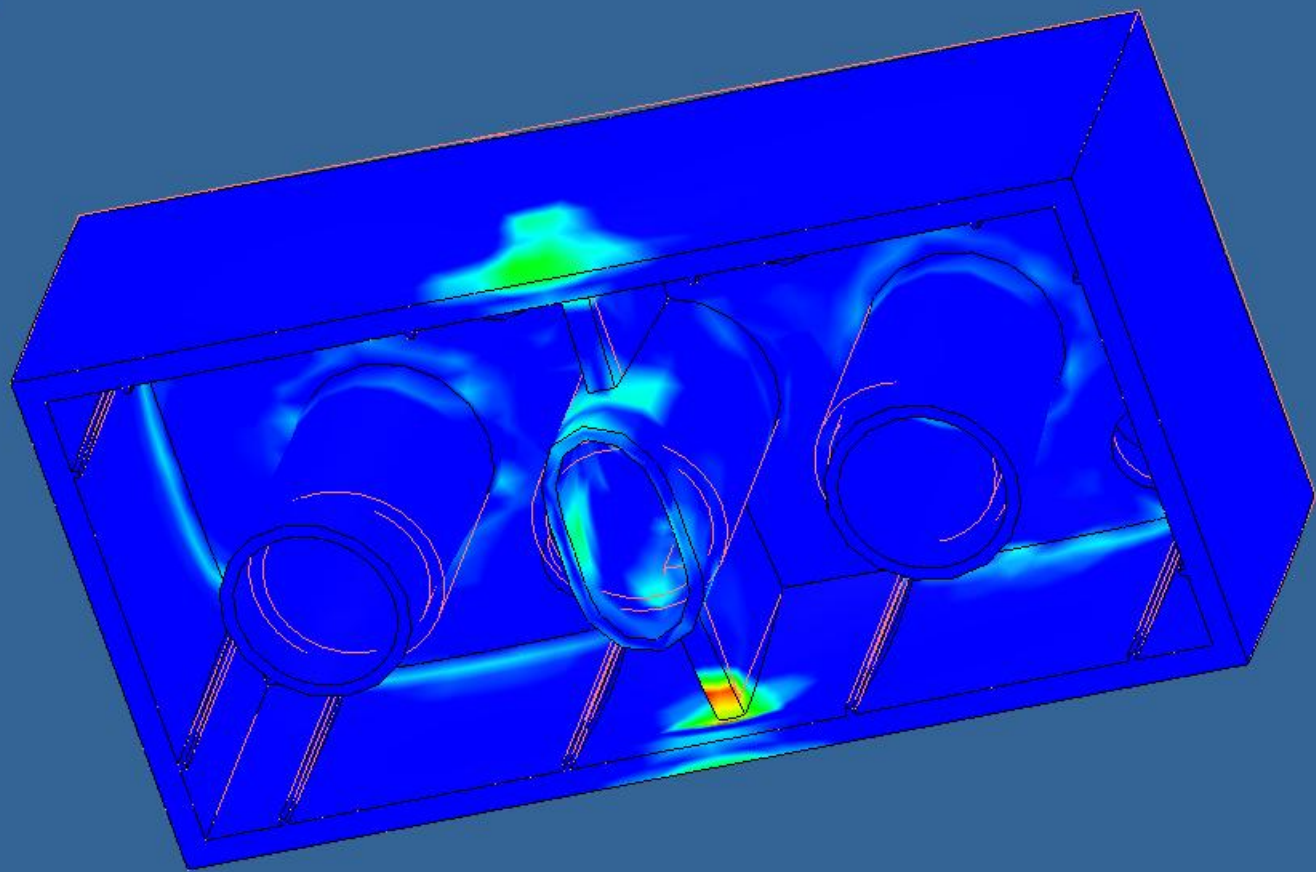
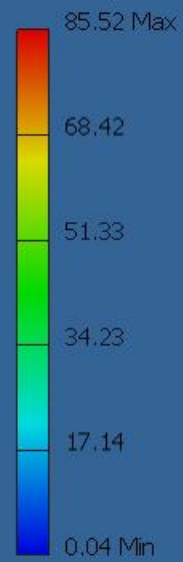

RAPID PROTOTYPING Z-CORP

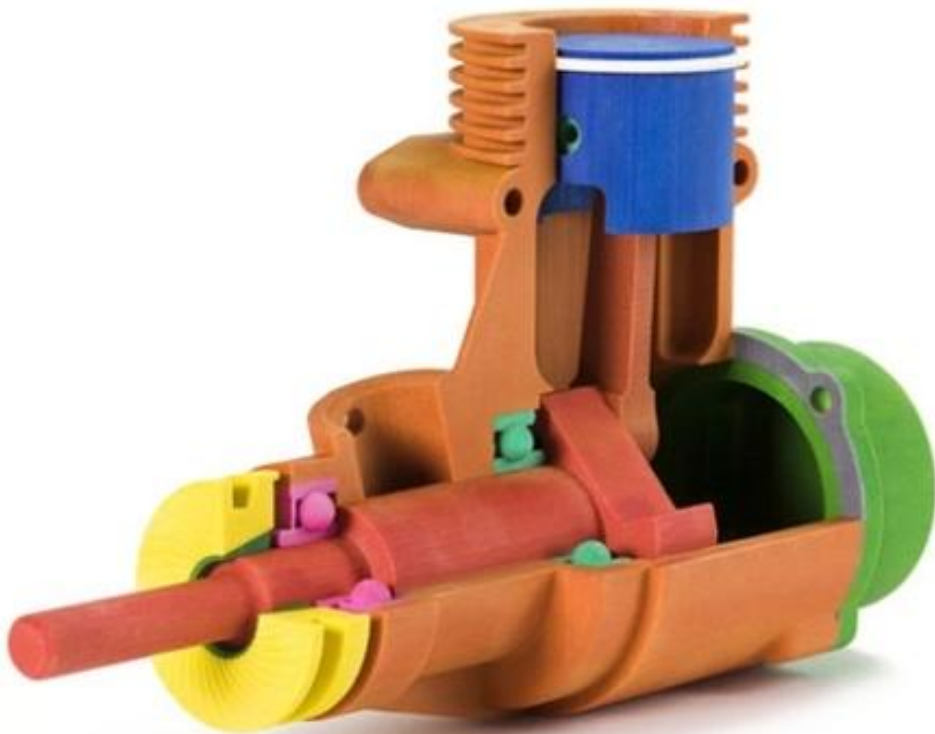

RAPID PROTOTYPING SLS (SELECTIVE LASER SINTERING)

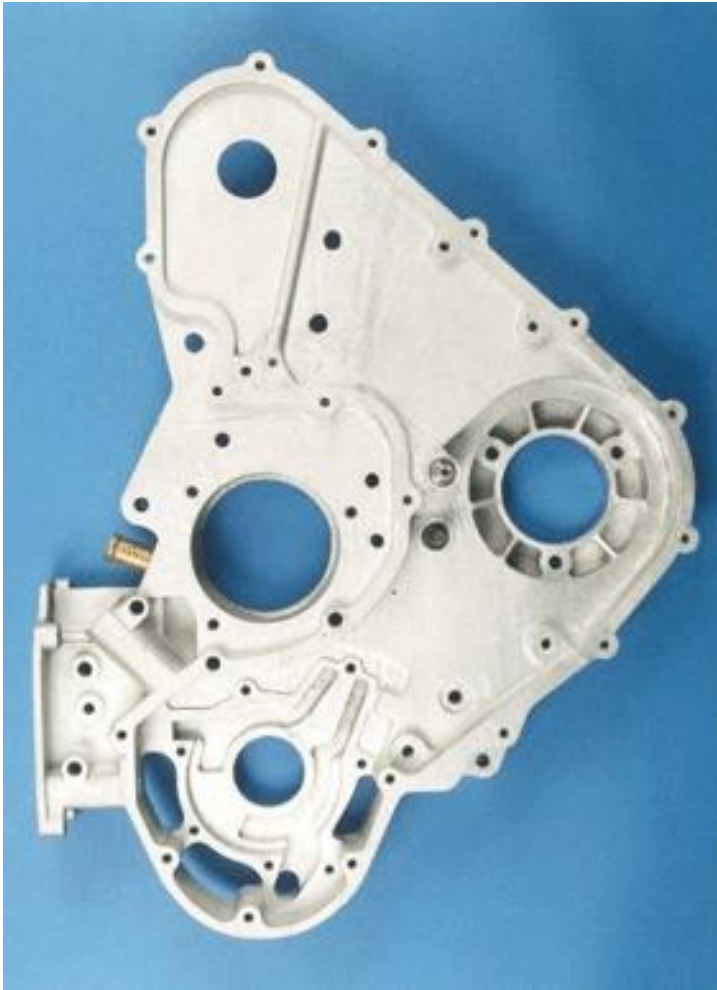

RAPID PROTOTYPING

FDM (FUSED DEPOSITION MODELING)

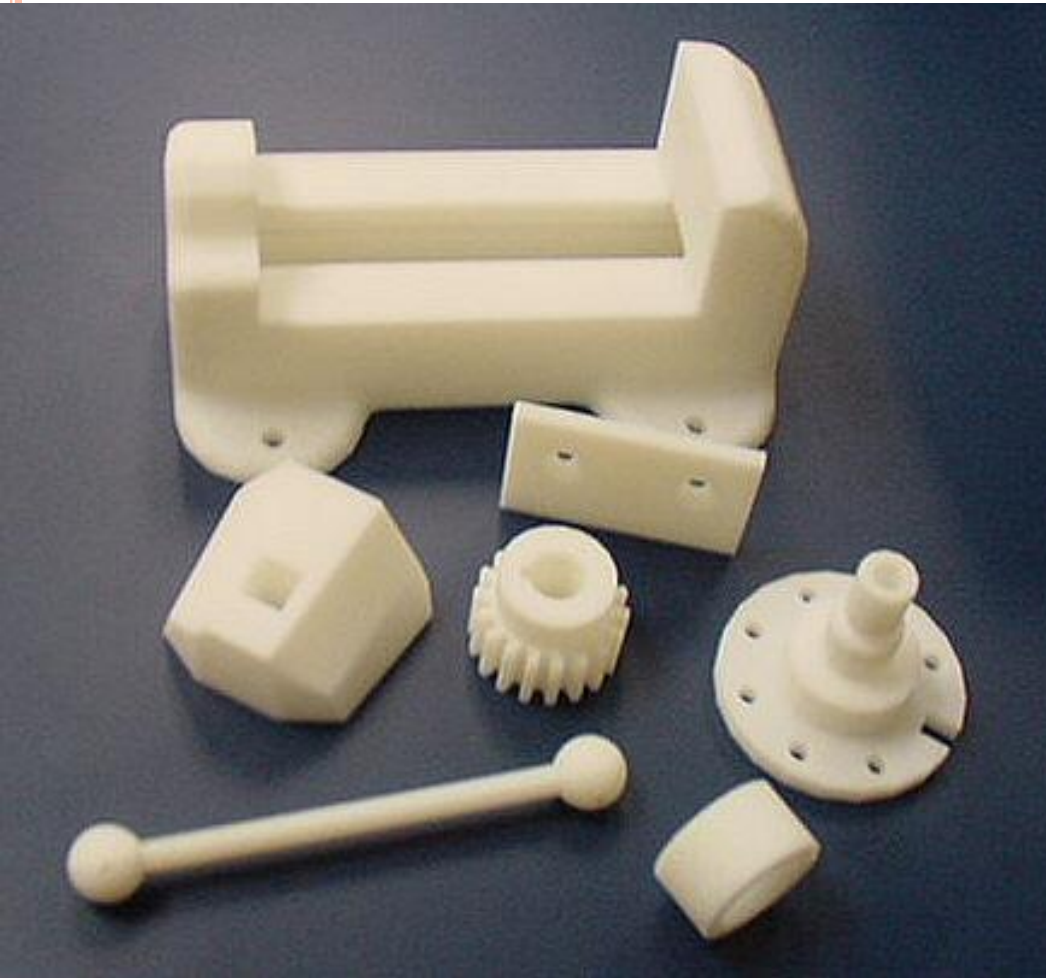

RAPID PROTOTYPING THERMOJET



RAPID PROTOTYPING SLA (STEREOLITHOGRAPHY)

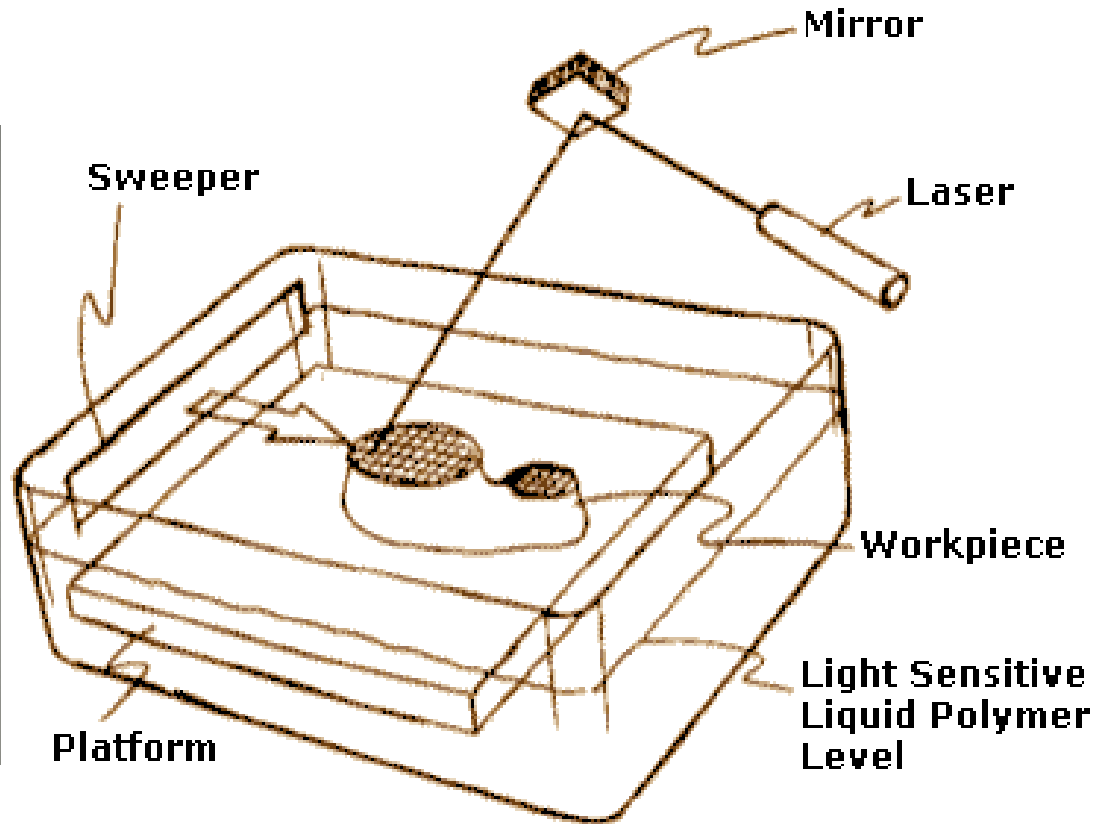



HALO 3





GAMESPOT



Microsoft
Flight Simulator X



MOD SIM/ DIGITAL PROTOTYPE VARIATION

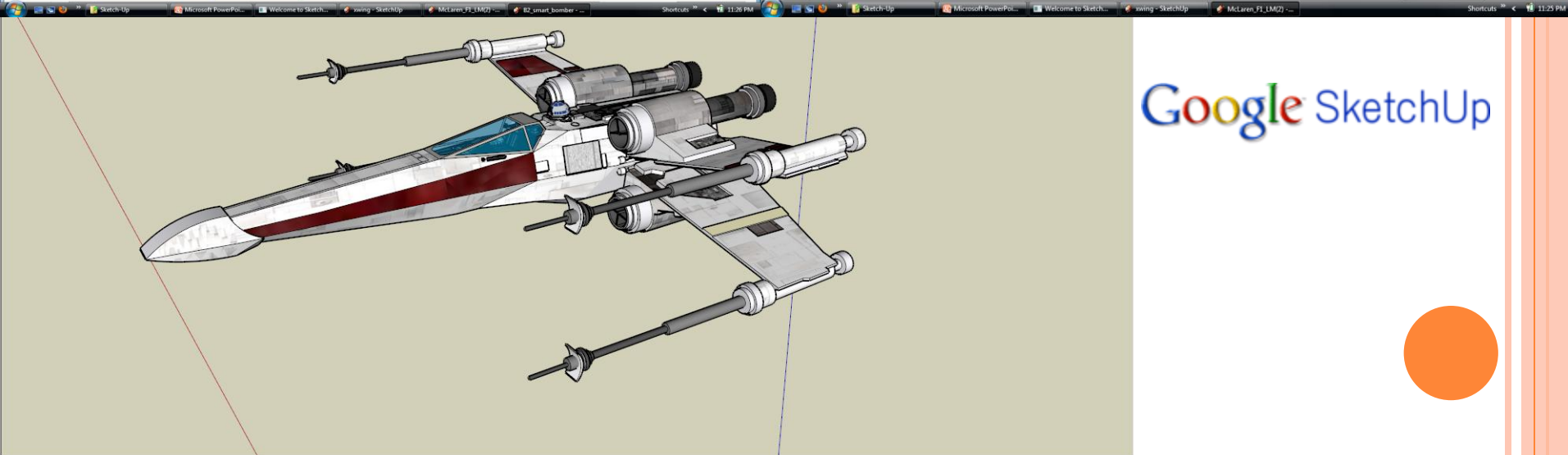
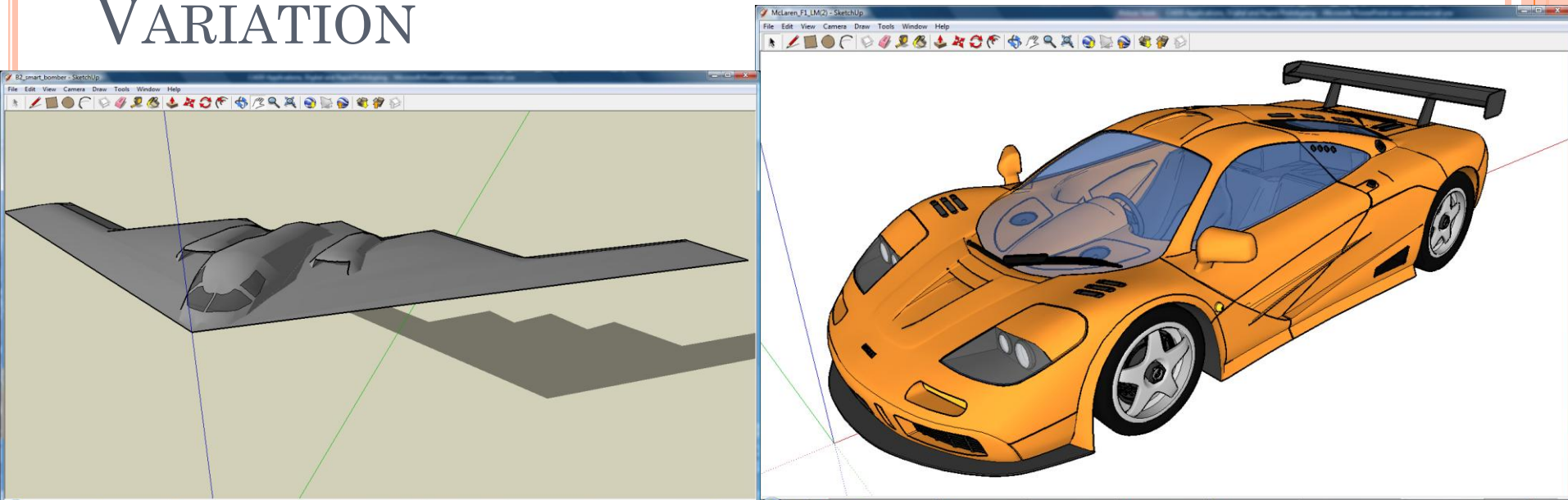

Google SketchUp



MATERIAL SCIENCE VARIATION



YOUR VARIATION

- The sky is the limit for the variations to the last half of this presentation. What will you do for your students?

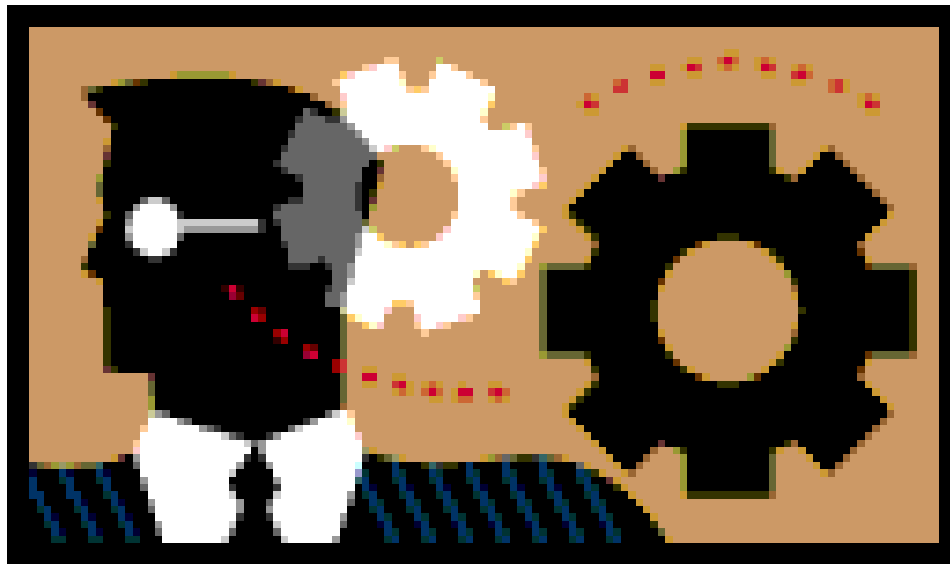

QUESTIONS?

